

614-737-8850 • 1-877-898-8850

## Under-counter Refrigerator

### Top:

Constructed of heavy gauge 300 series stainless steel #3 finish.

### Exterior:

Heavy gauge stainless steel fronts and sides. The rear, bottom and compressor housing are constructed of heavy gauge galvanized steel.

### Interior:

Entire liner is constructed of heavy gauge stainless steel with adjustable powder coated wire rack(s).

### Refrigeration:

Wasserstrom exclusive "slim line" unit cooler design, is recessed inside the rear refrigerator wall to offer maximum unobstructed storage and to facilitate cleaning. The evaporator shroud is constructed of stainless steel for dent and corrosion resistance. The evaporator coil is provided with a thermal expansion valve for quick recovery and the coil is double coated with a special epoxy coating for protection against corrosion caused by food acids and cleaning chemicals. The condensing unit is positioned for easy serviceability and it is provided with an energy-saving hot gas condensate evaporator that saves on electricity. The entire cabinet is foamed-in-place with high density polyurethane insulation up to 3" thick for maximum energy efficiency.

### Doors:

Fronts and liners are constructed of heavy gauge stainless steel and foamed-in-place with high density polyurethane insulation and welded corners. Doors are provided with magnetic gaskets for positive seals and they are fitted with heavy-duty die cast hinges.

### Tailored to Your Needs:

Just one of the benefits of our complete in-house design, fabricating and manufacturing capabilities, is the fact that any of our Refrigerated Cabinets can be tailored to fit your exact functional needs and interior décor preferences. Just let us know what you want, and our professional design staff will make it a reality.



AUCR-Series

### Standard features:

- Stainless steel interior and exterior. Galvanized rear and bottom
- Hot gas condensate evaporator uses no electricity.
- Heavy-duty casters
- Electronic temperature controller for maximum accuracy with LED display
- Coated evaporator coil for protection against corrosion.
- Heavy-duty refrigeration system with expansion valve environmentally friendly R-404a
- 8 ft. long electrical cord included

AUCR1B27

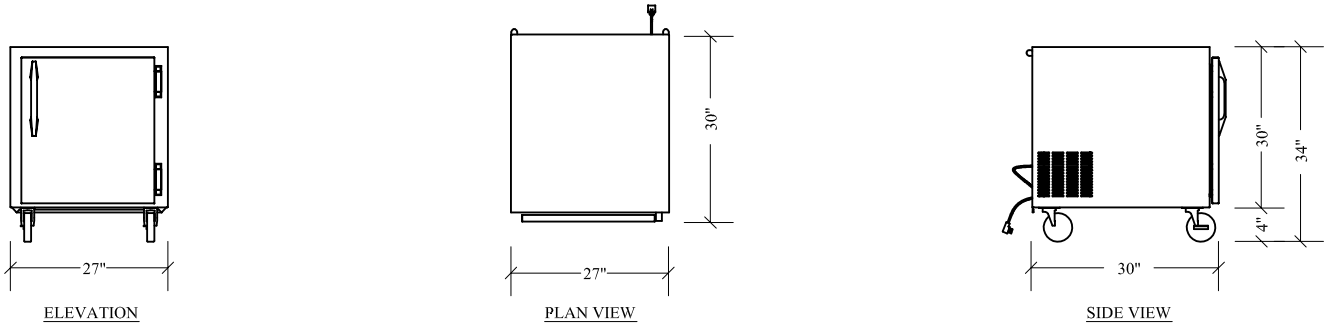

AUCR1B48

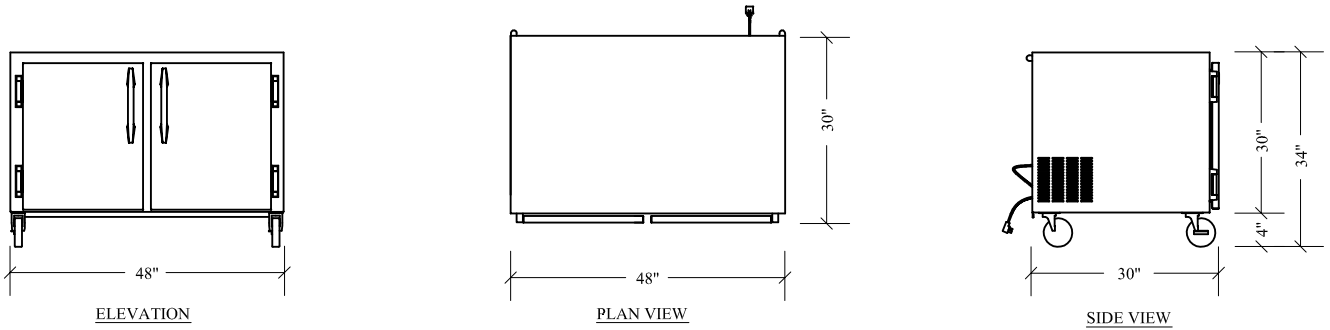

AUCR1B60

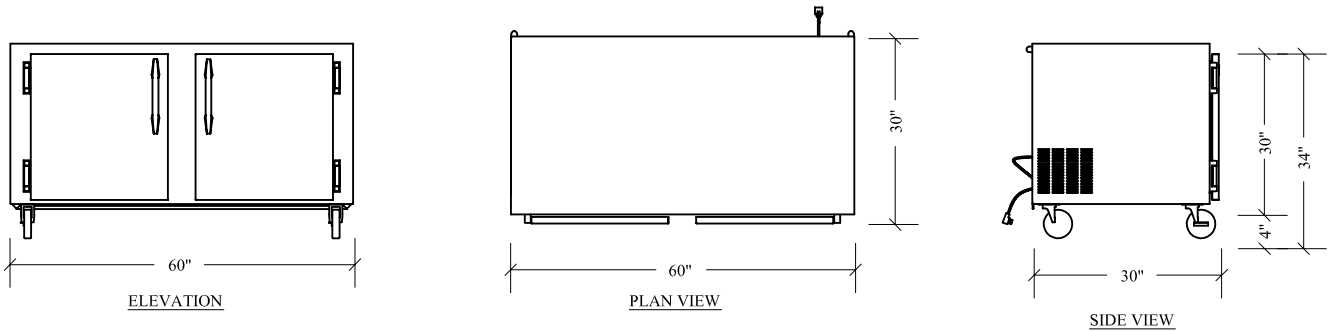

AUCR1B72

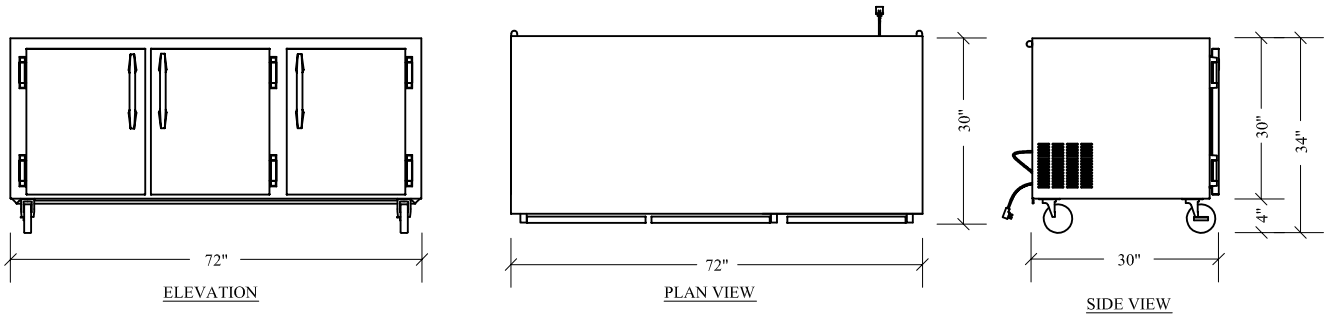

PART #	LENGTH	DEPTH	HEIGHT	NUMBER OF DOORS	COMPRESSOR	AMPS	VOLTAGE	SHIP WEIGHT
AUCR1B27	27"	30"	34"	1	$\frac{1}{5}$	5.41	115/60/1	344
AUCR1B48	48"	30"	34"	2	$\frac{1}{5}$	5.41	115/60/1	429
AUCR1B60	60"	30"	34"	2	$\frac{1}{5}$	5.41	115/60/1	470
AUCR1B72	72"	30"	34"	3	$\frac{1}{3}$	8.7	115/60/1	531